

Specification Sheet

FX122G2 Combistar



Product Description:

- The Angelo Po CombiStar FX is a versatile and advanced cooking system designed to meet the demands of commercial kitchens. With its programmable controls and touch display, this oven allows for precise and efficient cooking.

Cooking Programs:

- 99 programs with 4 phases.
- Standard 3 re-heating programs, 5 smoking, 4 Low Temperature, and 1 Delta T.
- Pre-Setting for vacuum core probe accessory and smoke accessory.

Technology and Features:

- Data selection control knob and backlit touch-sensitive keys.
- SC2 washing system with double-action sanitization effect and ECO function.
- RDC (patented) + EVOS steam generator with low management cost and dual-level steam generation system DSG.
- Manual steam injection and automatic cooling and preheating.
- Interface for HACCP data downloading on printer (optional).
- Provision for remote peak power cut and cooking chamber siphon drain to prevent backflow of liquids and smells with T pipe for ventilated downstream installation.
- Armoured direct heat exchanger in incoloy 800 in cooking chamber, cooking fan, and steam generator in AISI 316L stainless steel.
- Ceramic fibre thermal insulation with an anti-radiation barrier.
- Control panel protected by 5 mm of tempered glass, deflector panel between the cooking chamber and exchanger/fan opening on hinges for services and cleaning.
- Door with intermediate stop positions at 90° and 130° and double-tempered glazing with open-cavity and internal low emissive glazing, internal removable glazing, and rock wool.
- Handle with double handgrip and high-strength silicone door seal with two heat barrier lines.
- Condensation collection and drain built-in tray, and all operating elements located near the technical compartment on the left-hand side of the oven.

Capacity

- 12 x 2/1GN - 24 x 1/1GN
- Wide range of accessories for various cooking processes such as grilling, braising or baking

Convection Heat

- 50°F - 572°F (10°C - 300°C)
- 0% - 100% Humidity

Steam

- 86°F - 257°F (30°C - 125°C)

Combination

- 6°F - 482°F (30°C - 250°C)
- 0% - 90% Humidity



Specification Sheet - FX122G2 Combistar



Model	FX122G2 Combistar
Working voltage	230V 1N~ / 50Hz
Net weight	496.04 lbs
Gross weight	584.23 lbs
Packing width	51.97 in
Packing height	55.91 in
Packing depth	44.88 in
Width	46.38 in
Height	47.05 in
Depth	42.91 in
Electric power	0.95 kW
Gas power	32.5 kW
Electric supply height	18.50 in
Gas diameter	3/4"
Gas supply height	18.50 in
Cold water	13.47 gal/h
Cold water diameter	3/4"
Cold water connection hgt	18.50 in
Water drain diameter	4 in
Water drain height	0.39 in
Dimensions	46.38x42.91x47.05 in
Packing	51.97x44.88x55.91 in
Door opening	from left to right
Capacity in GN containers	12 x 2/1GN - 24 x 1/1GN
Portions for cooking process	n° 335
Product core probe	Singlepoint, standard
Display	Segment digital
Power supply	Gas
Installation Requirements	Hood Installation is Required for Cooking Smoke; The Oven Must Be Installed Level; Install Water Supply Shut-Off Valve and Back-Flow Preventer
Clearance Requirements	Left side of equipment: 20" from heat source and 19" recommended for service access. Minimum clearance 6-1/2" - When left side clearance is less than 20" from a heat source, please inquire about an Angelo Po heat shield accessory. Right: Min. clearance 3-57/64".

It is highly recommended that the Angelo Po reverse osmosis water treatment systems, as well as Angelo Po brand cleaning chemicals (CL55XL detergent and BR55XL brightener) be used and incorporated into all Angelo Po Combistar combi oven installations. It is the sole responsibility of the owner / operator / purchaser of the Angelo Po equipment, to verify that the incoming water supply is comprehensively tested to meet the Angelo Po water compliance standards, published in this document. Non-compliance with the Angelo Po water standards noted herein could potentially damage the equipment and/or VOID the original manufacturer's standard warranty.

Specification Sheet

FX122G2 Combistar

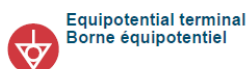
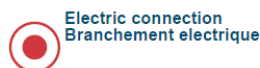
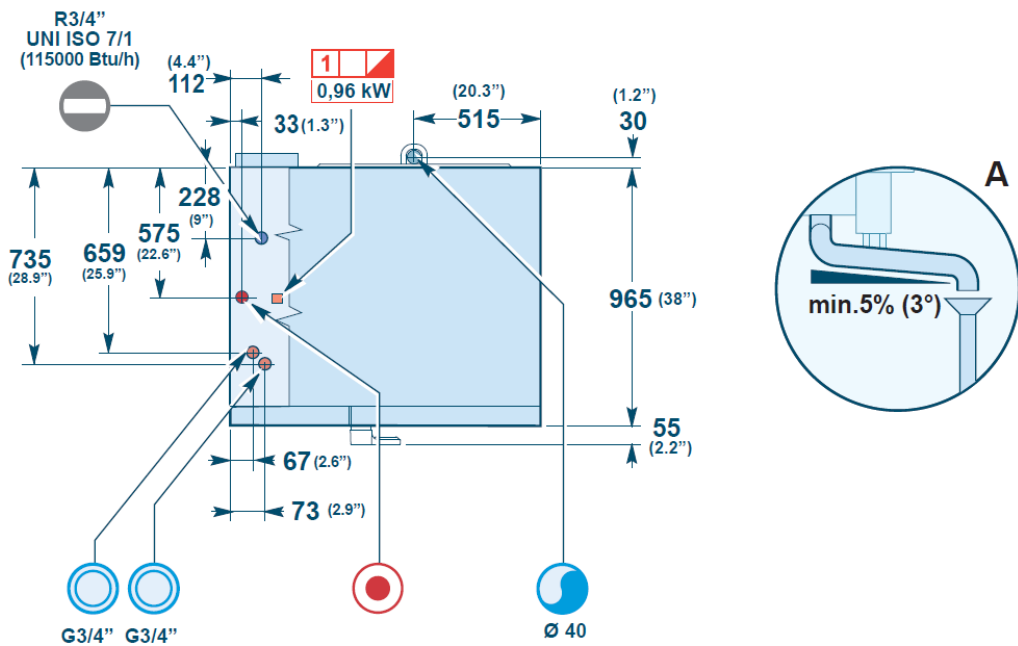
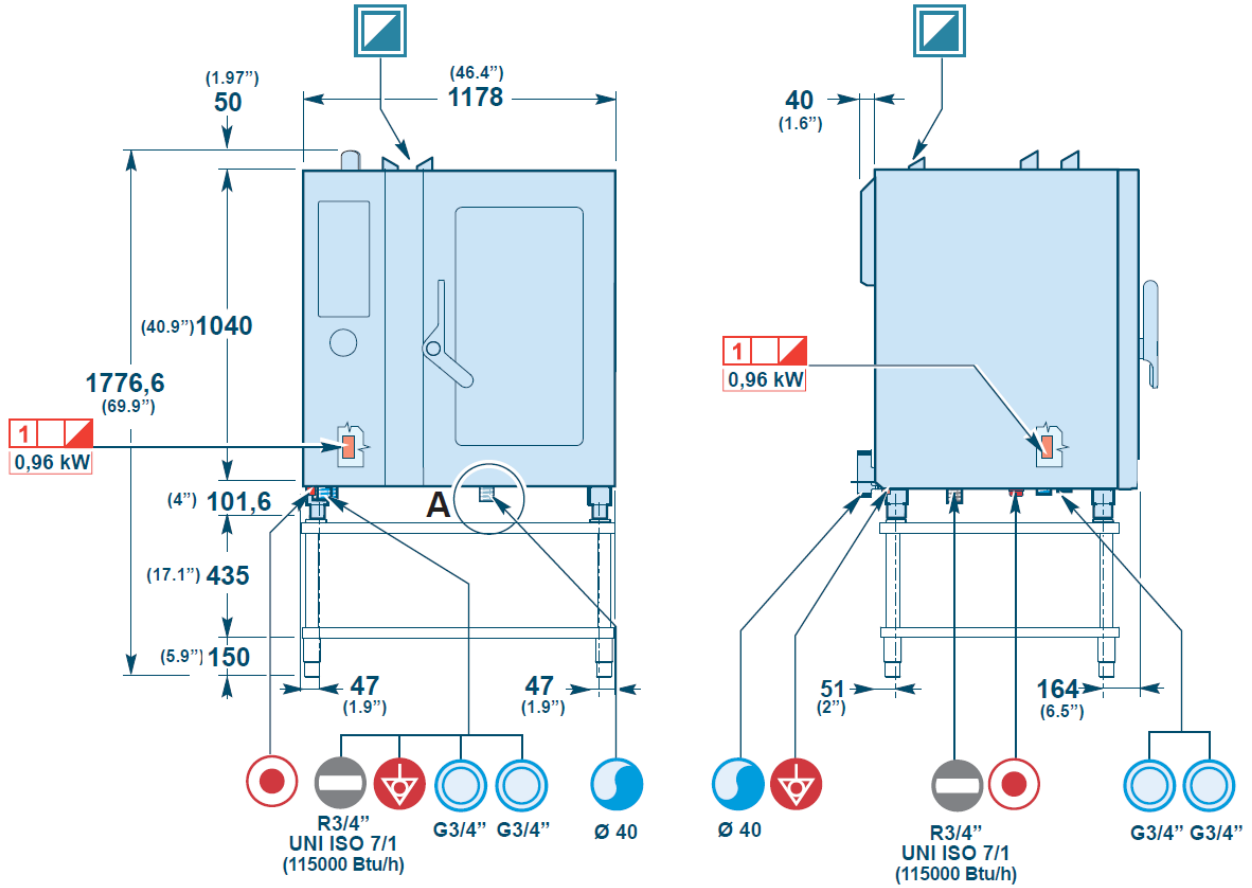

Unit of measurement = mm / in
Unité de mesure = mm / in